

ULTRASONIC WELDING

THE OLD BUT GOLD TECHNOLOGY



YOUR PARTNER
IN PLASTIC JOINING

ULTRASONIC WELDING

The “old but gold” technology!

This is a type of “spot welding”, the evolution of screwing technology, suitable for those components which don't need for simultaneous welding joining of the entire welding path.

The ultrasonic welding process is based on the conversion of friction and vibration energy into heat. Using a welding tool called «sonotrode», the high-frequency ultrasonic acoustic vibrations are transferred to the components. These vibrations are generated by the ultrasonic system, which sends an alternating current. The ultrasonic energy melts the contact point between the two parts, creating a joint.

Somebody calls the ultrasonic welding as “the old technology”, because it is the oldest technique in plastic joining. Nevertheless, this technology is still **very competitive** in various welding fields, due to the **great versatility, flexibility and cost-effectiveness** that characterize it.

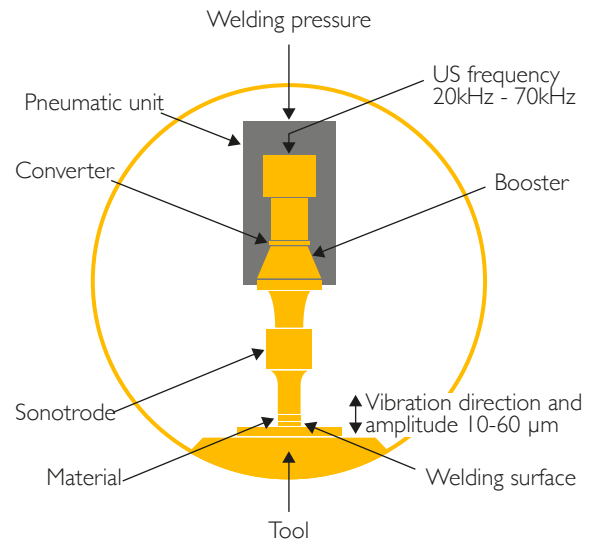

For these reasons, we have decided to invest in this welding system and to modernize it, not by changing its application mode, but by technologically improving it: we have developed a range of fully electric ultrasonic welding machines. Therefore, **our machines are more precise, faster and cleaner than before**, and able to ensure more control, more welding steps and more precise regulations of all the welding parameters.

Thanks to this technological modernization, nowadays ultrasonic welding constitutes **a valid and efficient alternative**, even if compared to the most modern joining welding technologies.

TYPICAL SETUP

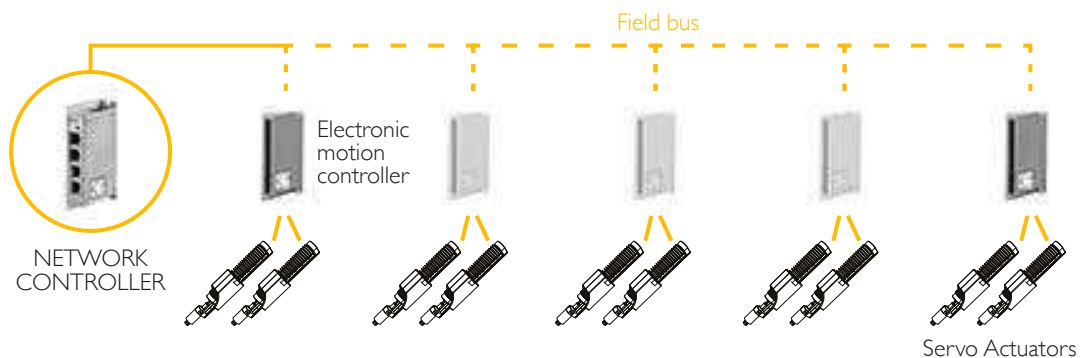

BENEFITS

- Current loop 40 μ s
- Position loop 80 μ s
- Network based drive control
- Very small drives size, no need for electrical cabinet
- Cross link connection
- No cooling fans

- Highly precise thrust control
- Highly precise welding depth control
- Format change, diagnostics, realtime status check (position, speed, thrust)
- Compact machine
- Easy maintenance
- Quietness

APPLICATIONS

No limits in customization

The ultrasonic welding machines must always be designed and "shaped" based on the material and the geometric characteristics of the components that have to be welded.

However, there are some machines which, except for certain minor changes, may be considered as a standard.

Mercedes, Volkswagen and FCA, three of the most important world automotive brands, have relied on CEMAS ultrasonic welding machines to join some of their products.



Volkswagen Touran
(Dashboard)



Fiat Tipo
(Dashboard)



Fiat Tipo
(Door panels)



Mercedes Viano
(Door panel)



Mercedes Viano
(Dashboard)



STRONG POINTS



SPEED

This welding technology is much faster than conventional adhesives or solvents.



SAFE

This type of welding is not dangerous to humans, indeed the vibrations are called ultrasonic because they are at frequencies higher than those that can be heard by the human ear.



NO LIMITS

Ultrasonic welding technology can weld almost any geometry.



LOW MAINTENANCE

Thanks to its full electrical nature, this technology doesn't require high level of maintenance.



VERSATILE

With the PC Panel it is possible to have a perfect traceability for all welding parameters (in particular welding energy, force and depth) up to 100.000 welding parts.



TIME SAVING

The cooling time is very quick, and the pieces do not need to remain inside the tool for a long period of time to dry or cure the welding joint.



MADE FOR YOUR NEEDS

Although there are some "standard model" machines, each ultrasonic welding machine is designed specifically and "around" to the component that must be welded.

Indeed, in our headquarters in Carmagnola we provide customers with a laboratory where they can carry out any welding test. Thanks to the know-how and experience of our team, we take care of your projects during the entire production cycle, from initial design to final implementation. We develop for you and with you the most efficient ultrasonic welding machines by a "customization" process of the equipment.

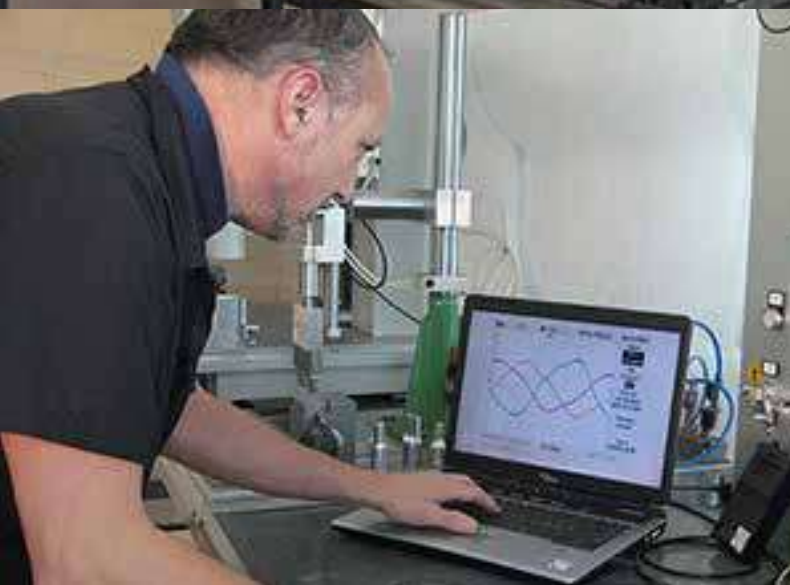



No compromise for quality!



To integrate our welding machines we use **only top class materials and components**, the best on the market, manufactured by world leading suppliers. The components we choose are **never from sub-brands**: this ensures the best performances in terms of speed, productivity and versatility.

Safety and efficiency are our ultimate goal.

ULTRASONIC COMPONENTS
powered by



ELECTRONIC COMPONENTS
powered by

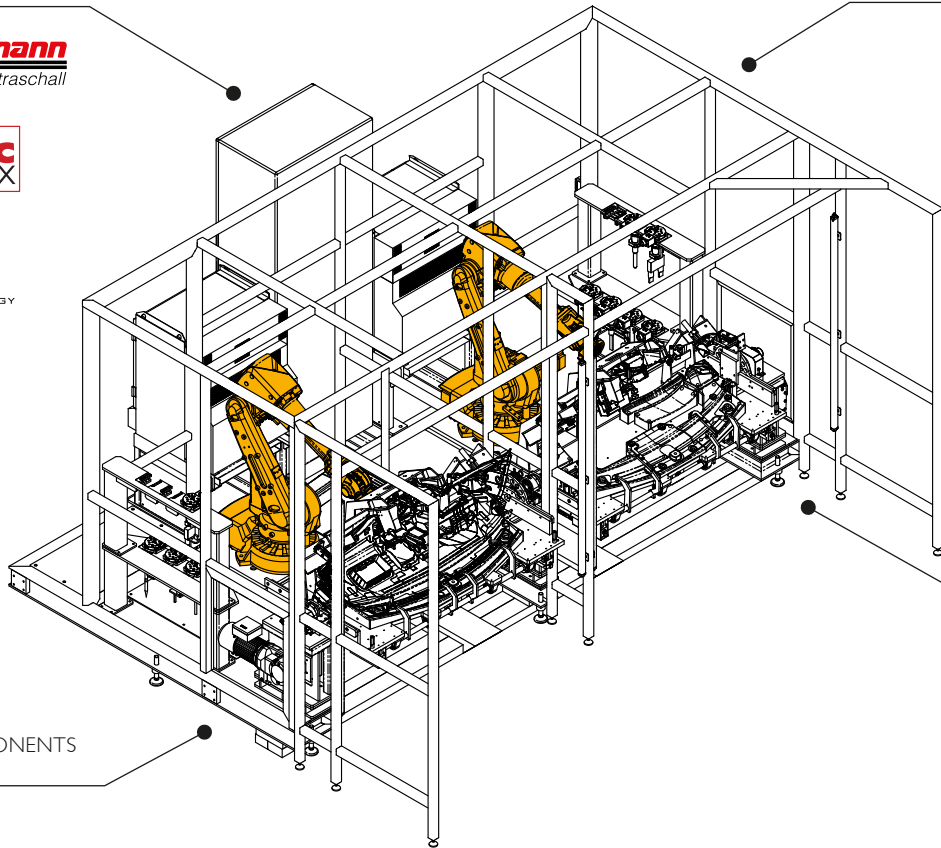

PNEUMATIC COMPONENTS
powered by



ROBOT SYSTEM
powered by



ANY TYPE OF COMPONENT

The wide range of applications related to this technology allows us to weld any type of component.

- rear and front lamps
- door trim panels
- bumpers
- instruments panel

- engine components
- packaging (pallets, boxes, etc.)
- electronic appliances
- etc.

● PRODUCTION PLANTS



Italy CEMAS Elettra
info@cemaselettra.com



Germany CEMAS Germany
info@cemas-germany.com



Brasil CEMAS do Brasil
info@cemasdobrasil.com.br



Mexico CEMAS México
mexico.sales@cemaselettra.com



Turkey CEMAS Türk
turkey.sales@cemaselettra.com



China CEMAS China
china.sales@cemaselettra.com

● TECHNICAL AND COMMERCIAL OFFICES



France CEMAS France
france.sales@cemaselettra.com



Portugal/Spain CEMAS Iberica
iberica.sales@cemaselettra.com



Russia CEMAS Russ
russia.sales@cemaselettra.com



UK CEMAS UK powered by Xfurth Ltd
uk.sales@cemaselettra.com



Poland CEMAS Polska powered by KaniTech
polska.sales@cemaselettra.com



Romania CEMAS Romania
romania.sales@cemaselettra.com

■ OFFICIAL DEALERS

USA/Canada **EXTOL**
sales@extolinc.com



CEMAS ELETTRA S.R.L.
Strada degli Occhini, 23
10022 Carmagnola (TO)
Italy

P +39 011 97 12 096
F +39 011 97 73 922
info@cemaselettra.com
www.cemaselettra.com